

# Sub-Terahertz Wireless Communications Technologies

T. Nagatsuma<sup>(1)</sup>, A. Hirata<sup>(1)</sup>, R. Yamaguchi<sup>(1)</sup>, H. Takahashi<sup>(1)</sup>,  
T. Kosugi<sup>(2)</sup>, M. Tokumitsu<sup>(2)</sup>, K. Murata<sup>(2)</sup>, T. Furuta<sup>(2)</sup>, and H. Ito<sup>(2)</sup>

<sup>(1)</sup>*NTT Microsystem Integration Laboratories*, <sup>(2)</sup>*NTT Photonics Laboratories*,  
*NTT Corporation*  
*3-1 Morinosato Wakamiya, Atsugi,*  
*Kanagawa 243-0198, Japan*  
*Email:ngtm@aecl.ntt.co.jp*

## Abstract

Demand is increasing for higher data rate in wireless communications in order to keep up with the remarkable speed-up of fiber-optic networks such as Ethernet LANs. One of the most effective approaches to achieve much higher data rate of >10 Gbit/s is to increase carrier frequencies to the sub-terahertz regime, 100 GHz and higher.

We have proposed the use of the 120-GHz band for 10-Gbit/s wireless link [1-3]. In our initial system demonstration, we have employed photonic technologies in the sub-terahertz transmitter as shown in Fig. 1. An optical sub-terahertz source generates optical subcarrier signals whose intensity is modulated at a frequency of 125 GHz. An optical intensity (ASK) modulator modulates the optical subcarrier signal using data signals. The modulated subcarrier signal is amplified by an optical amplifier and input into the photonic sub-terahertz emitter. In the emitter, a photodiode converts the optical signals into sub-terahertz signals, which are amplified and radiated toward the receiver via an antenna. The received sub-terahertz signals are amplified and demodulated by a simple envelope detection scheme.

We have developed a low-phase-noise tunable optical sub-terahertz source based on optical heterodyning [4]. Optical signals are converted to sub-terahertz signals using a uni-traveling carrier photodiode (UTC-PD) and amplified by an InP-HEMT power amplifier (Fig. 2). The maximum output power from the amplifier-integrated UTC-PD now exceeds 10 dBm at 120-GHz band [5]. The sub-terahertz receiver is composed of all-electronic devices using the same InP-HEMT technology (Fig. 3) [6]. An MMIC chip for all-electronic transmitters has recently been tested successfully.

Figure 4 is a photograph of the photonics-based transmitter setup for a long distance (>1 km) link using a high-gain Cassegrain antenna. The 120-GHz-band wireless link system was licensed by the Japanese Ministry of Internal Affairs and Communications as the first experimental radio station using >100-GHz electromagnetic waves (output power: 0 dBm) in July 2004, and its upgraded version (output power: 10 dBm) was licensed in August 2005. This wireless link can support both of 10 GbE (10.3 Gb/s) and OC-192 (9.95 Gb/s) with a BER of  $10^{-12}$ . We have also succeeded in the wireless transmission of 6-channel uncompressed high-definition television (HDTV) signals using the link.

## References

- [1] A. Hirata et al., *IEEE J. of Lightwave Technol.*, 21, pp. 2145-2153, 2003.
- [2] A. Hirata et al., *IEEE Trans. Microwave Theory Tech.*, 52, pp.1843-1850, 2004.
- [3] A. Hirata et al., *IEEE Trans. Microwave Theory Tech.*, 54, pp.1937-1944, 2006.
- [4] A. Hirata et al., *IEICE Trans. Electron.*, E88-C, pp. 1458-1464, 2005.
- [5] H. Ito et al., *IEICE Electronics Express*, 2, pp.446-450, 2005.
- [6] T. Kosugi et al., *Tech. Dig. Compound Semiconductor IC Symposium*, H. 6L, 2004.

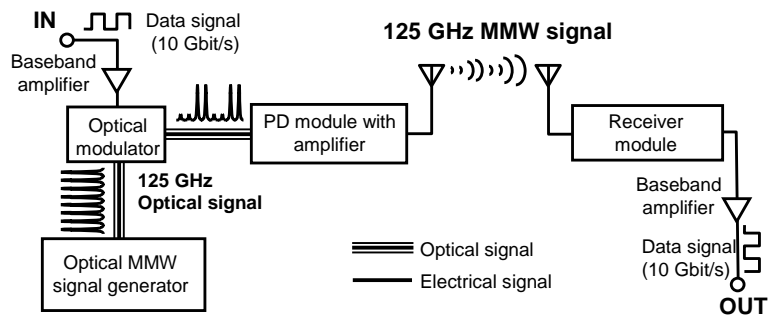

**Fig. 1.** Block diagram of a 120-GHz-band wireless link system.

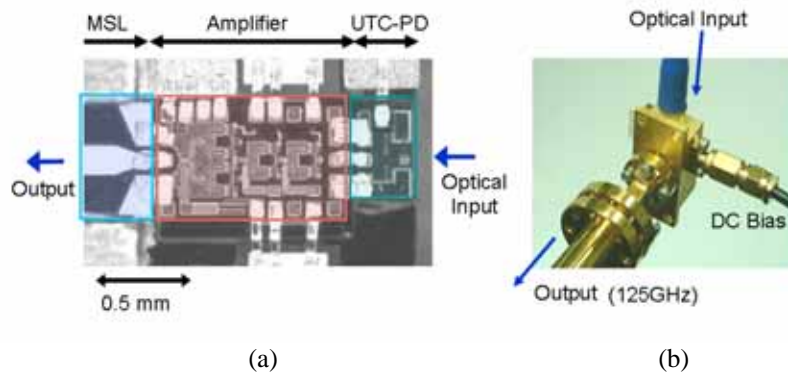

**Fig. 2.** 120-GHz-band emitter. (a) Integrated structure. (b) Packaged module.

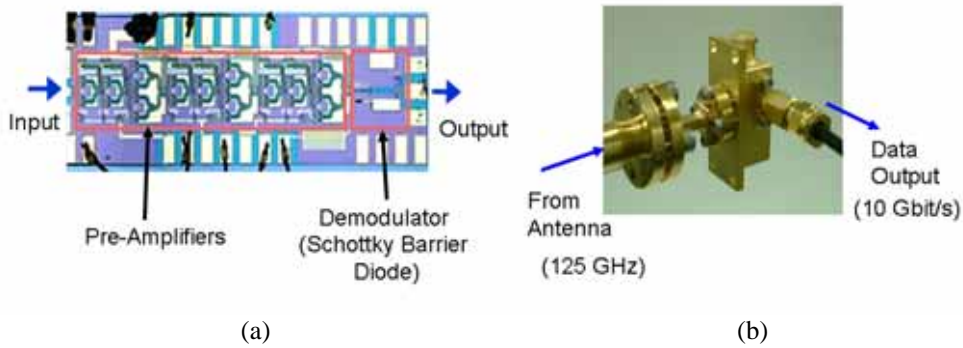

**Fig. 3.** 120-GHz-band receiver. (a) MMIC chip. (b) Packaged module.

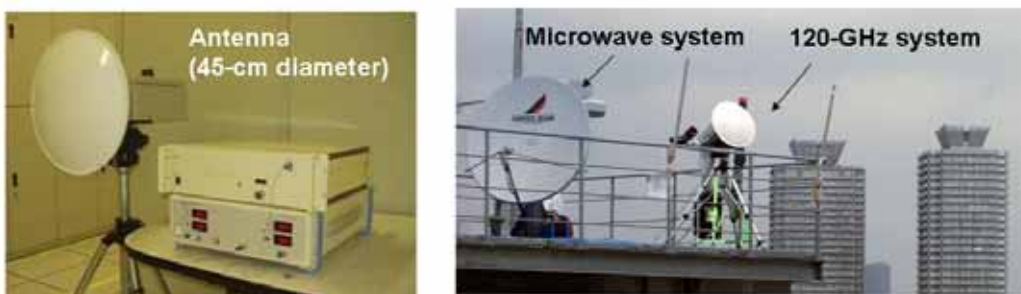

**Fig. 4.** Photographs of the transmitter front end and its setup for the field trial.